

AXM 217S: Motorised actuator for unit valves with positioner

How energy efficiency is improved

Automatic adaptation to valve and intelligent cut-off for maximum energy efficiency

Features

- Stepping motor with electronic activation and cut-out
- Attached to valve with M30 × 1.5 thread
- Version with direction of operation 1 (direct acting) or 2 (reverse acting), adjustable
- Adjustable valve strokes
- Automatic stroke adjustment (AXM217SF404)
- Maintenance-free gear unit
- Suitable for retrofitting existing installations using the appropriate adapters
- Status and diagnostic indicator via integrated bi-colour LED
- Fitting position vertically upright to horizontal, not suspended



AXM217SF402

AXM217SF404



Technical data

Power supply

Power supply	24 V~/=, ±15%, 50...60 Hz
Power consumption	2.5 VA

Parameters¹⁾

Direction of operation	1 or 2 (adjustable)
Nominal stroke	3.2 mm, 4.3 mm, 5.5 mm (adjustable) Automatic stroke adjustment (F404)
Running time	8 s/mm
Sound pressure level	< 30 dB(A)
Control signal	0(2)...10 V; 5...10 V; 0...5 V R _i > 100 kΩ; 0(4)...20 mA R _i = 500 Ω

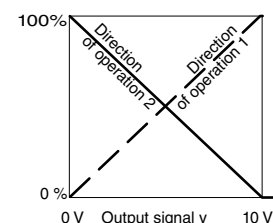

Ambient conditions

Admissible ambient temperature	0...50 °C, no condensation
Max. operating temperature at valve	95 °C
Storage and transport temperature	-20...65 °C
Admissible ambient humidity	< 75% rh

Construction

Weight	0.15 kg
Housing	Two-part, light grey (RAL7035)
Housing material	Plastic
Thread	Nickel-plated brass M30 × 1.5
Power cable	1.50 m long, 3 × 0.5 mm ² , light grey, pluggable 3.0 m long, halogen-free (F404)

Standards and directives

Type of protection	IP43 (EN 60529)
Protection class	III (IEC 60730)
CE conformity according to	EMC Directive 2014/30/EU 61000-6-1, 61000-6-2, 61000-6-3 and EN 61000-6-4

¹⁾ The direction of operation and the control voltage can be set using DIP switches; factory setting "2" (RA).
Direction of operation 1: Control signal increasing = actuator moves out (valve VUT, VUL, VCL, VDL, BUL closes and valve BXL (control passage) opens). Direction of operation 2: Control signal increasing = actuator moves in (valve VUT, VUL, VCL, VDL, BUL opens and valve BXL (control passage) closes).



Overview of types

Type	Properties	Actuating power
AXM217SF402	Motorised actuator for unit valves with positioner	120 N
AXM217SF404	Motorised actuator for unit valves with positioner and automatic stroke adjustment	160 N

 AXM217SF402: Actuating power min. 100 N, max. 150 N

Accessories

Type	Description
0550603009	Cable: 24 V, PVC, pluggable, 3 m long
0550603010	Cable: 24 V, PVC, pluggable, 7 m long
0550603011	Cable: 24 V, halogen-free, pluggable, 3 m long
0550603012	Cable: 24 V, halogen-free, pluggable, 7 m long
0371235001	Adaptor for fitting to Oventrop valves (M30 × 1)
0550393002	Adapter for fitting to Danfoss valves, type RAVL, 26 mm
0550393003	Adapter for fitting to Danfoss valves, type RAV, 34 mm
0371356001	Adaptor for fitting to Beulco or Tobler underfloor-heating distributors (M30 × 1)
0371361001	Adapter for fitting to Herz valves, type Herz-TS'90 (M28 × 1.5)
0371363001	Adapter for fitting to Tour & Andersson valves, type TA/RVT (M28 × 1.5)
0550393004	Adapter for fitting to Danfoss valves, type RA 2000, 22 mm

Description of operation

Auto-calibration: During commissioning (with valve fitted), the spindle of the actuator moves completely to the bottom (zero point). Then the spindle moves to the position that corresponds to the control signal. **Confirmation of the end position:** When the actuator has been in its start or end position for a lengthy period, every 2 hours the control signal is activated for around 60 seconds. This automatically recalibrates the actuator. The motor positions the valve and cuts out as soon as the stroke position matches the controller signal. The LED indicator lights up if power is applied and flashes as long as the motor is running.

Direction of operation 1:

- As the positioning signal increases, the actuator spindle moves out and the VUL, VUT, VCL, VDL 2-way valves and the BUL 3-way valve (control passage) close. With the BXL 3-way valve, the control passage opens.

Direction of operation 2:

- As the positioning signal increases, the actuator spindle moves in and the VUL, VUT, VCL, VDL 2-way valves and the BUL 3-way valve (control passage) open. With the BXL 3-way valve, the control passage closes.

After the cap on the cover is removed, the following settings can be made using jumpers:

- Setting of the input signal. This can be set to either 0...10 V or 5.2...10 V or 0...4.8 V.
- Direction of operation 1 or 2 can be selected; the factory setting is direction of operation 2 (RA).

Put the cap back on after making the settings.

Automatic valve stroke detection (AXM217SF404 only)



Note:

To function properly, the actuator requires a valve with a preloading of at least 2 kg.

To detect the valve stroke, the actuator moves the spindle all the way to both end positions after the operating voltage is applied.

By measuring the position of the spindle, the total stroke of the valve is calculated and stored in the actuator. As soon as the calibration cycle (flashing red LED) is completed, the actuator goes into normal mode (constant green LED).

End position confirmation (AXM217SF404 only):

If the actuator is in its end position (100%) for an hour, the position is identified again.

The actuator spindle is then moved for around 60 seconds according to the control signal in order to redetermine the end position.

LED status indicator

Status	Description
OFF	No power applied
Flashing green	Actuator moving to position or "end position reached"
Continuous green light	Position reached
Flashing red	Calibration cycle
Continuous red light	No input signal, 4-20 mA or 2-10 V

Intended use

This product is only suitable for the purpose intended by the manufacturer, as described in the "Description of operation" section.

All related product regulations must also be adhered to. Changing or converting the product is not admissible.

Engineering and fitting notes

Do not use tools to fit the actuator to the valve. In the event of a power failure, the valve can be opened by taking off the actuator. When connecting or changing the power cables, the mains power must be switched off. The actuator may be fitted to the valve only when the actuator spindle is not fully (100%) moved out. It is delivered ex works at 0% stroke.

Outdoor installation

We recommend protecting the devices from the weather if they are installed outside buildings.

Disposal

When disposing of the product, observe the currently applicable local laws.

More information on materials can be found in the Declaration on materials and the environment for this product.

Connection diagram

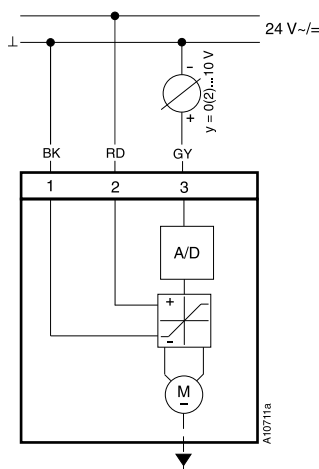

1	BK (black)
2	RD (red)
3	GY (grey)

Dimension drawing

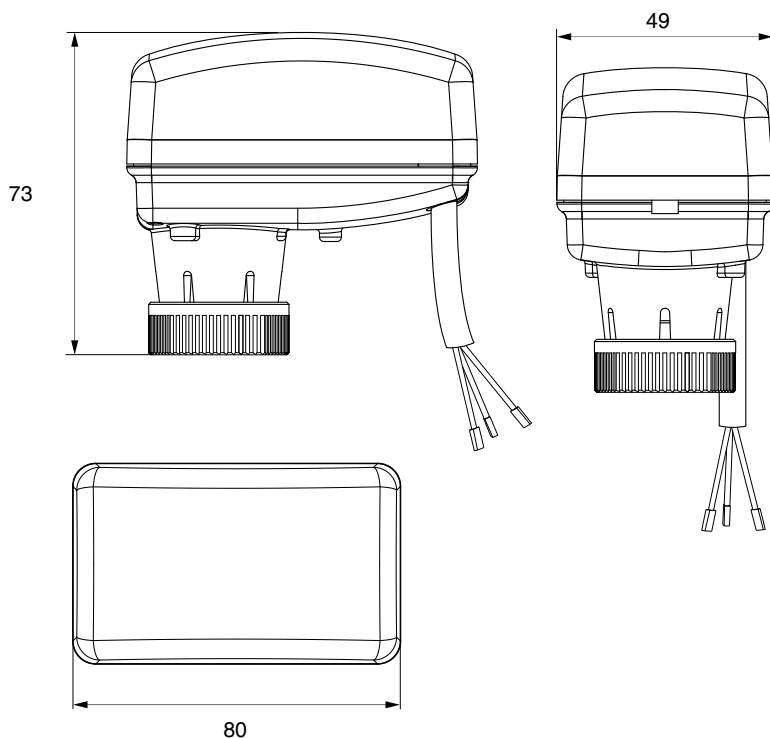

DIP switch setting

DIP SWITCH OPTIONS

<input type="checkbox"/> 0, ..10VDC	<input type="checkbox"/> 0, ..5VDC	<input type="checkbox"/> 5, ..10VDC	<input type="checkbox"/> 2, ..10VDC
<input type="checkbox"/> 0, ..20mA	<input type="checkbox"/> 4, ..20mA	<input type="checkbox"/> 4, ..20mA	<input type="checkbox"/> 4, ..20mA
<input type="checkbox"/> DA	<input type="checkbox"/> RA	<input type="checkbox"/> LIN	<input type="checkbox"/> Eq%
<input type="checkbox"/> VDC	<input type="checkbox"/> mA		

1: CONTROL SIGNAL RANGE
2: CONTROL SIGNAL RANGE
3: CONTROL SIGNAL RANGE

4: ACTION
5: CURVE
6: SIGNAL TYPE

DIP switches 1-2-3-6

DIP switches 1-2-3 are used for setting the control signal range. The voltage (VDC) or current (mA) is set with DIP switch 6.
As delivered ex works: DIP switches 1-2-3-6 in OFF position

DIP switch 4

The direction of operation of the actuator is set with DIP switch 4:
Direction of operation 1: DA (Direct Acting)
Direction of operation 2: RA (Reverse Acting)
As delivered ex works: DIP switch 4 in ON position

DIP switch 5

This switch can set the actuator so that the characteristic of the combination of valve with actuator corresponds to a linear or equal-percentage characteristic.

DIP switch 5 in OFF(LINE) position

Use this setting if the valve has a linear or equal-percentage characteristic.

DIP switch 5 in ON (Eq%) position

Use this setting with an OPEN/CLOSE or high-speed valve.

As delivered ex works: DIP switch 5 in OFF position

AXM217SF402 stroke setting

The stroke can be set using a jumper.

As delivered ex works: 3.2 mm