

Notes

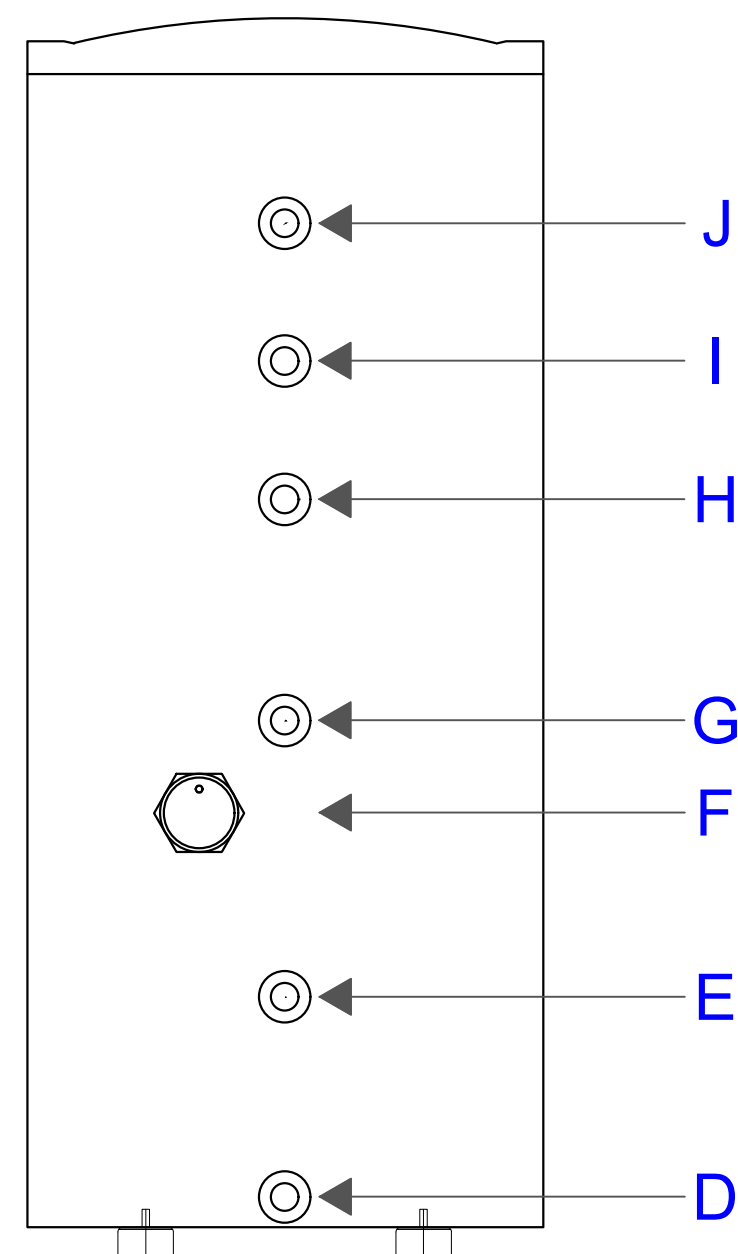

Connections		M/F	Size	Colour
A	Exhaust	F	G 3/4"	Red
B	Coil Inlet	F	G 1"	Red
C	Coil Outlet	F	G 1"	Blue
D	Drain	F	G 3/4"	Blue
E	Cold Water Inlet	F	G 1"	Blue
F	Electric Heater (Immersion)	F	G 1 1/2"	Red
G	Temperature Sensor	F	G 1/2"	Blue
H	Magnesium Anode	F	G 3/4"	Red
I	Temperature Sensor	F	G 1/2"	Blue
J	Hot Water Outlet	F	G 1"	Red

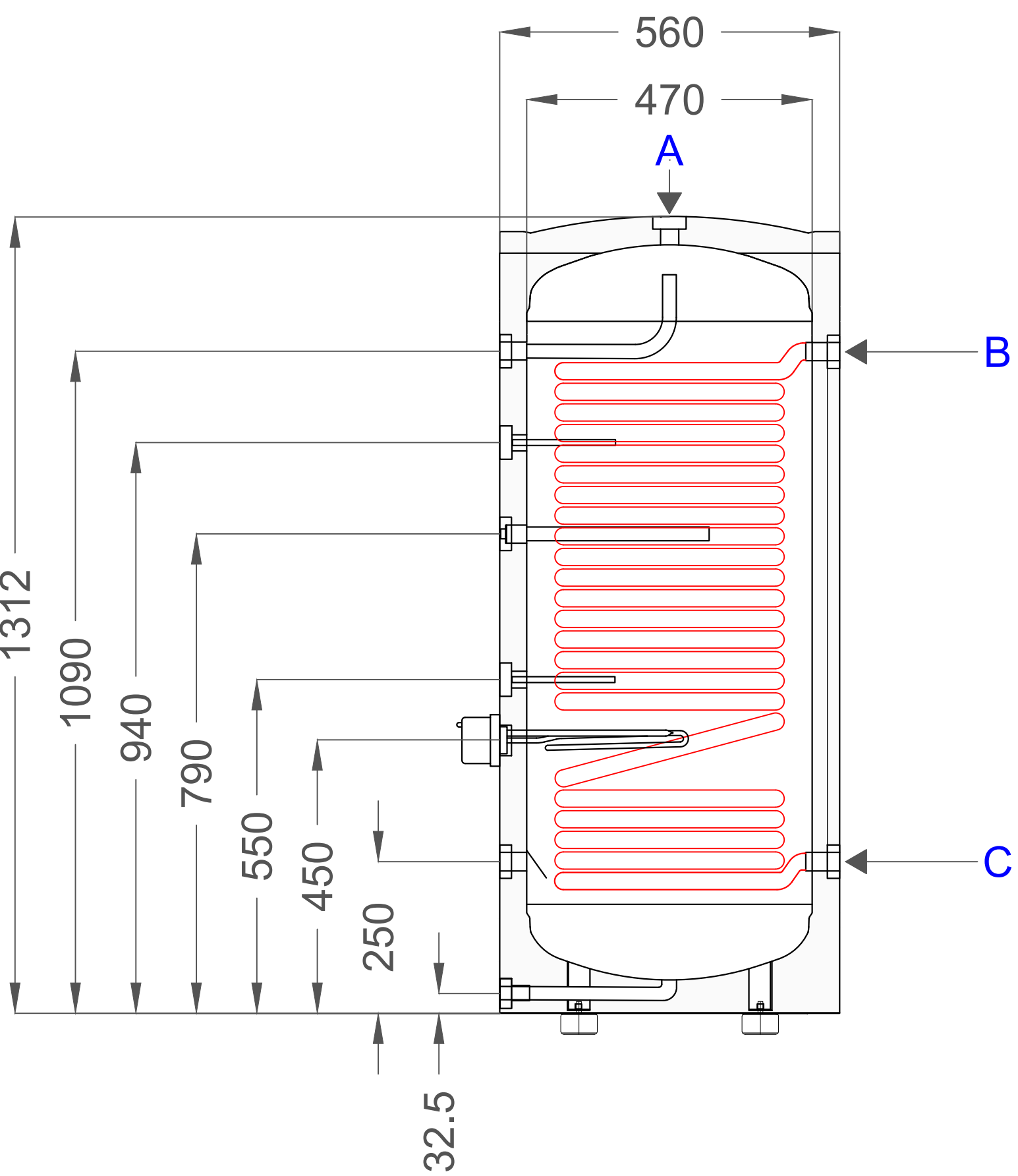
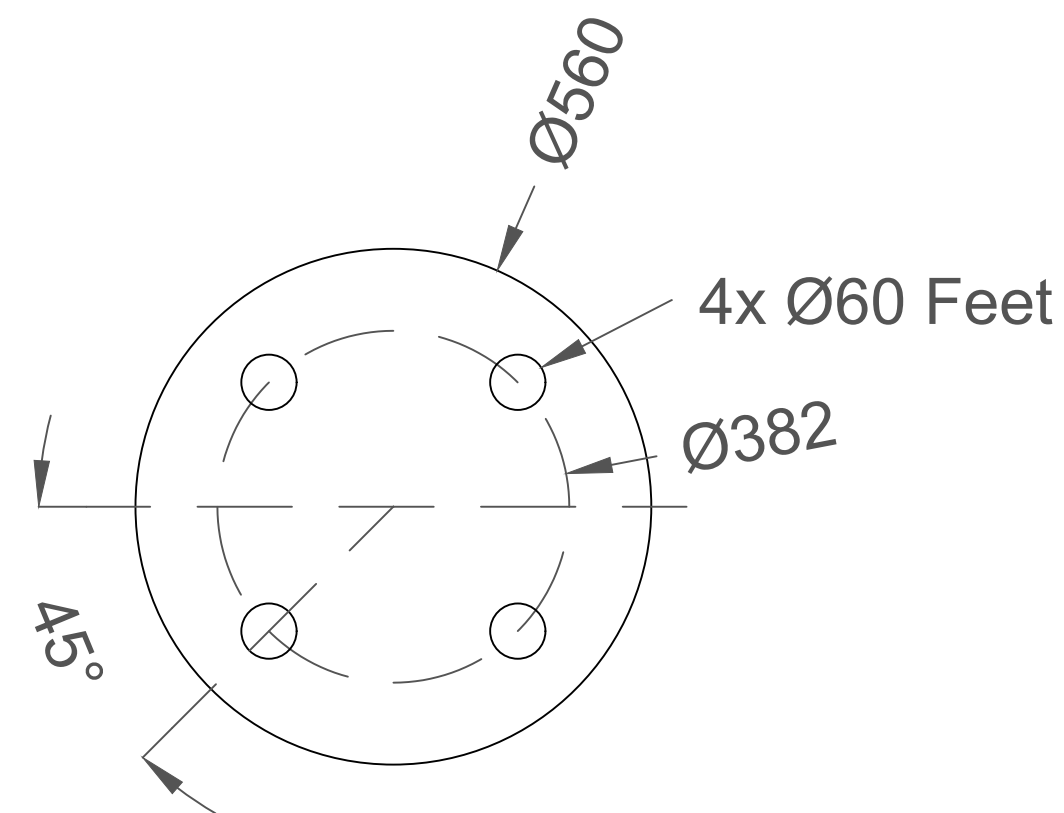
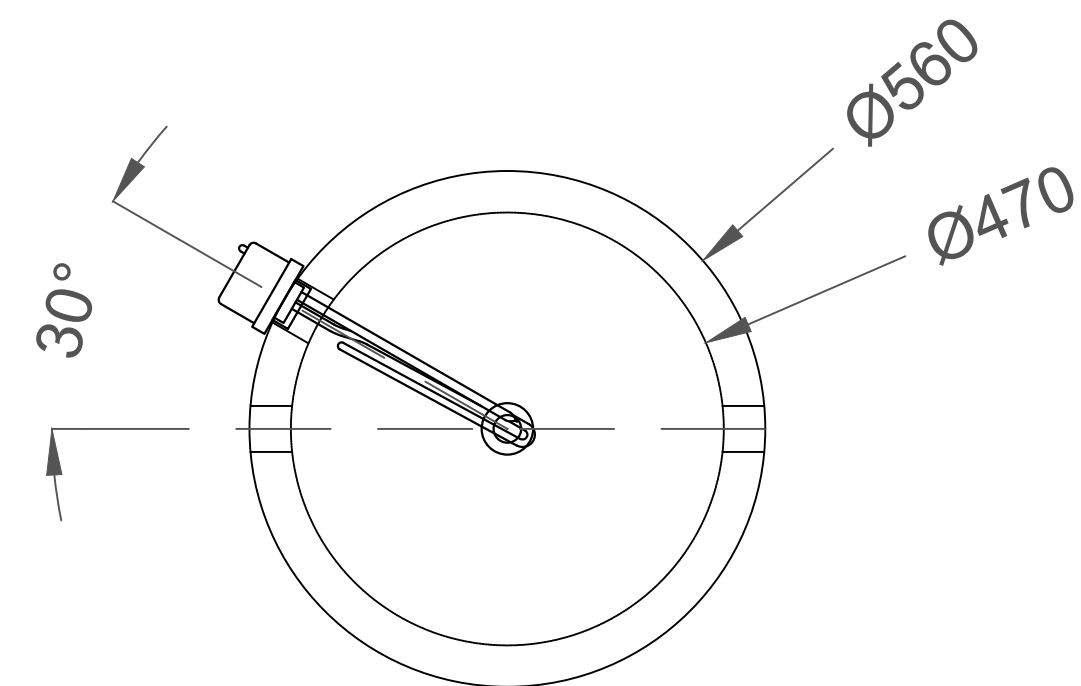

Legend



NRG Awareness Telephone: +353 214 355728
 Unit 8, Little Island Industrial Estate Email: info@nrgawareness.com
 Little Island, Co. Cork Website: NRGawareness.com

Project Name

ECO 200 L High Recovery Cylinder

Drawing Title

Dimensions and Connections

Designed By	Checked By	Date	Revision
-------------	------------	------	----------